

ROLE OF EFFECTIVE COMMUNICATION IN EMPOWERING ENTREPRENEURS FOR ECONOMIC GROWTH AND DEVELOPMENT IN IBAJI LOCAL GOVERNMENT AREA OF KOGI STATE

Attah Udeh Samuel

No 7B University Market Road, Nsukka, Enugu State.

Email: attahsamuel021@gmail.com

Phone No: 09062158923

Abstract

Effective communication is the backbone of an entrepreneurs for a successful business operation there by promoting economic growth and development. Strategic communication is what keeps things moving forward smoothly for entrepreneurial success. The study examines the impact of effective communication on economic growth and development in Ibaji Local Government Area of Kogi State, with a focus on empowering entrepreneurs. The correlation between entrepreneurial success and economic growth and development is a nonnegotiable. However, effective communication strategies is a must requirement for entrepreneurial success. The research aims to investigate the relationship between communication strategies and entrepreneurial success, as well as the role of communication in fostering economic development. A mixed-methods approach was used, combining surveys, interviews, and focus groups with entrepreneurs and stakeholders in the area. The findings shall also reveal the effective communication strategies and its impact on entrepreneurial success, and economic growth and development. From the findings, the study recommends that, there is a need to develop a comprehensive Communication Strategy for Entrepreneurs in Ibaji Local Government Area in order to enhance their business growth. Secondly Entrepreneurs should invest in communication skills training to improve their ability to effectively communicate with stakeholders. Finally, implementation of policy interventions should be made to support entrepreneurship, such as tax incentives, grants and access to finance.

Key words: Entrepreneurs, Empowering, Communication, Strategies, Economic Growth and Economic Development.

Introduction

The correlation between entrepreneurial success and economic growth and development is a nonnegotiable. However, effective

communication strategies is a must requirement for entrepreneurial success. Effective communication serves as the driving force behind economic transformation, bridging gaps and unlocking new opportunities. It fosters collaboration among key stakeholders, facilitates informed decision-making, and amplifies the voices of marginalized communities. Our communication initiatives span advocacy campaigns, innovation, sustainable tourism, and economic development, aiming to raise awareness about critical socio-economic issues and propel progress toward sustainable development goals. By harnessing a range of communication strategies, we strive to inspire behavioral change, disseminate vital information, engage stakeholders, and cultivate constructive dialogue."

Entrepreneurship plays a crucial role in economic development (Śledzik, 2013). It refers to "a dynamic process whereby an individual called "entrepreneur" or a group of individuals either explores or establishes and operates business opportunities in order to produce additional products and deliver new services to the market" (Auschra et al., 2019). In essence, it is disruptive, as it requires a high innovation level and intervenes at a high risk-taking level to build new business models that reshape what was once the dominant model, this is what Schumpeter (1935) described as "creative destruction". This latter is an evolutionary process within capitalism that "revolutionizes the economic structure from within, constantly destroying the old, constantly creating the new" (Moloi and Marwala, 2020, p.01).

Entrepreneurial empowerment is essential not only to shape the mindsets of people but also to provide the skills and knowledge that are central to developing an entrepreneurial culture. Entrepreneurship provides individuals motivation, knowledge and skills necessary for launching a successful venture company (Cho, 2018).

"Community development empowers communities to reach their full potential through effective communication. This enables collaborative effort, engaging citizens, especially marginalized groups, in development initiatives. Communication facilitates collective change, shifting focus from individual to community-centered participation and equity.

In rural development, communication involves exchanging information, knowledge, and skills through various channels (radio, print media, telephones, internet) to improve livelihoods. The goal is to promote participation, mobilization, decision-making, awareness, knowledge sharing, and behavior change.

Statement of Problem

Effective communication is the backbone of an entrepreneurs for a successful business operation there by promoting economic growth and development. Strategic communication is what keeps things moving forward smoothly for an entrepreneurial success (Munteanu and Maciuga 2021). This kind of communication serves as the foundation that holds teams, shareholders, and customers together, ensuring that everyone works towards common objectives (Markovic and Salamzadeh 2018).

Despite the critical role of entrepreneurship in driving economic growth and development, entrepreneurs in Ibaji Local Government Area of Kogi State face significant challenges in communicating their needs, accessing information, and navigating institutional environments. The prevalence of inadequate communication strategies, limited access to information and communication technology (ICT), and poor networking opportunities hinder the potential for entrepreneurial growth and economic development in the region. It is against this backdrop that this study is conceptualized to examine the impact of effective communication on economic growth and development in Ibaji Local Government Area of Kogi State, with a focus on empowering entrepreneurs in the study area to bridge the gap in existing literature.

Objective of the Study

The main objective of this research work is to examine the roles of effective communication on economic growth and development in Ibaji Local Government Area of Kogi State with a focus on empowering entrepreneurs.

The specific objectives are to;

1. Examine the roles of effective communication on entrepreneurial growth in Ibaji Local Government Area
2. Examine how communication strategies can enhance economic development in Ibaji Local Government Area
3. Assesses the current state and challenges of entrepreneurship in Ibaji Local Government Area?

Significance of the Study

Belows are some of the significance aspect of the study;

- The key significance of the study is to improved communication strategies among entrepreneurs in Ibaaji Local area of Kogi Stata and Nigeria as a whole. It provides insights for entrepreneurs to

develop effective communication strategies, enhancing their business operations and relationships with stakeholders.

- The study aims to promote Economic Growth and Development by enhancing entrepreneurial success thereby contributes to the economic growth and development of Ibaji Local Government Area as well as Nigeria at large.
- Empowering Entrepreneurs with the necessary knowledge and skills for effective communication, thereby promoting entrepreneurial success and well-being.
- Contribution to Communication Theory: The study also contributes to the deep understanding of effective communication in business contexts and advancing communication theory and research.

Literature Review

Communication, the bedrock of business, is the most indispensable of all entrepreneurial skills. An entrepreneur's ability to transmit information helps both clients and customers feel they can communicate with and ultimately trust in the business. Communication is more important today than in previous years partly because the business and market conditions are more complex. The development of an effective communication strategy and its implementation can provide a number of benefits to an entrepreneurs and its business, such as keeping customers motivated and engaged, and sharing clear, consistent messages with customers in a timely manner that in turn help with business productivity (Charles, 1998).

Concept of Entrepreneurship

Entrepreneurship is a vital component of any economy, contributing significantly to job creation, wealth generation, poverty reduction, and income generation for governments and individuals (Dickson, Solomon, & Weaver, 2008). Its importance to economic growth and development cannot be overstated (Keister, 2005). Entrepreneurship is a key source of employment generation, with entrepreneurial activities having a positive impact on national economies and the quality of life for citizens (Adejumo, 2001).

Entrepreneurship encompasses more than just starting a business. It involves a process of identifying opportunities, allocating resources, and creating value by addressing unmet needs or capitalizing on opportunities for change (Ayandike, Emeh, &Ukah, 2012). At its core,

entrepreneurship is about innovation, transformation, and the creation of economic goods and services.

The Concept of Empowerment

Kabeer (2001) explained empowerment as the expansion in people's capacity to make strategic life choices in a context where this ability was previously denied to them. The position of Malhotra, Venneman & Kishor (1995) concurs with the definition by emphasizing that the definition highlights a transition from relieve powerlessness to a greater equity in the exercise of power and as such differentiate "empowerment" from the general concept of "power" as espoused by dominant individuals or groups. They argue further that to be considered empowered, youth themselves must be significant actors in the process of change. That is, youth must engage in agency. For example health and development strategies may support or enable youth's empowerment but they cannot provide empowerment as if they were health services or commodities themselves.

The concept of Effective communication

The word Effective means perfect or very well or the best Effective communication is the process of exchanging information, thoughts, and emotions in a way that ensures the message is clearly understood and received. It involves both speaking and listening, and it's about more than just conveying information.

According to (Berlo, 1960; Shannon & Weaver, 1949), effective communication is the process of sending exchanging information, ideas, thoughts, opinions, and messages between individuals, groups, or organizations in a clear, concise, and understandable manner. It involves the transmission, reception, and interpretation of information, as well as the exchange of feedback to ensure mutual understanding (Beebe & Masterson, 2012).

Relationship between effective communication and economic growth and development:

Numerous studies demonstrate the positive relationship between effective communication and economic growth and development:

1. Improved Business Performance: Effective communication enhances business performance, leading to increased productivity, profitability, and competitiveness (Gupta & Govindarajan, 2000).

2. Increased Foreign Investment: Countries with effective communication infrastructure attract more foreign investment, stimulating economic growth

3. Better Governance: Effective communication promotes transparency, accountability, and good governance, essential for economic development (Kaufmann et al., 2009; Transparency International, 2020).

4. Enhanced Innovation: Communication facilitates the exchange of ideas, driving innovation and economic growth

Effective communication contributes to economic growth and development through several mechanisms

1. **Information Dissemination:** Communication facilitates the dissemination of information, reducing information asymmetry and promoting informed decision-making

2. **Network Effects:** according to Granovetter, (1973), Communication enables the creation of networks, fostering collaboration, cooperation, and economic growth.

3. **Trust and Cooperation:** Effective communication builds trust and cooperation among stakeholders, essential for economic development

4. **Institutional Development:** Communication influences institutional development, promoting the creation of effective institutions that support economic growth (North, 1990; Acemoglu & Robinson, 2012).

"The Relationship Between Entrepreneurship and Economic Growth

Entrepreneurship is widely regarded as a vital driver of economic growth and development. Over the past three decades, countries that experienced significant poverty reduction have also seen a remarkable resurgence in entrepreneurial activity (Naude, 2013). The 1980s and 1990s witnessed a renewed focus on supply-side economics, small firms, and entrepreneurship due to stagflation and high unemployment.

To understand the link between entrepreneurship and economic growth, it's essential to decompose the concept of entrepreneurship (Wennekers & Thurik, 1999). Having examined entrepreneurship, economic growth, and economic development individually, we can now explore their interconnectedness.

The positive relationship between entrepreneurship and economic growth, first proposed by Schumpeter, is well-established. An increase in entrepreneurs leads to increased economic growth, driven by their innovative activities and skills. Schumpeter identified five cases of innovative activity:

1. Introducing new or unfamiliar goods or quality.

2. Implementing new, untested production methods.
3. Discovering new markets or expanding existing ones.
4. Developing new sources of supply.
5. Creating new organizational structures or management practices.

Importance of Communication Strategies for entrepreneurial Development in Ibaji Local Government of Kogi State.

Effective communication plays a vital role in the development of entrepreneurial rural communities Ibaji local government area of Kogi state. It provides a platform for community members to voice their concerns, express their needs, and actively participate in decision-making processes. Through effective communication, rural communities can bridge the gap between themselves and different stakeholders, such as governments, non-governmental organizations, and businesses, allowing them to convey their perspectives and realities. By encouraging dialogue, effective communication fosters understanding, empathy, and cooperation among community members and stakeholders. It establishes an environment where diverse opinions are welcomed and respected, leading to inclusive decision-making processes. As a result, rural communities can have a say in matters that directly affect their lives, such as infrastructure development, resource management, and social policies.

Effective communication is essential for rural development. It facilitates knowledge sharing within and outside rural communities, empowers marginalized groups, and enhances the capacity of communities to identify and address their own development priorities (Field, 2005).

Knowledge sharing: Effective communication enables the exchange of local knowledge, culture, and practices, while also providing opportunities for accessing external expertise and information. This exchange of knowledge empowers rural communities to address their challenges and develop innovative solutions.

Empowerment: Communication strategies play a crucial role in transforming social dynamics within rural communities. By promoting engagement and active participation, they empower marginalized entrepreneurs and indigenous communities, to have a voice in decision-making processes. This empowerment leads to a more democratic, inclusive, and equitable society. Additionally, communication strategies foster social cohesion, strengthen community networks, and build trust among community members.

Capacity building: Effective communication enhances the capacity of rural communities to identify and address their own development

priorities. By providing opportunities for reflection, learning, and interaction, communication strategies enable communities to identify their needs, challenges, and available resources. They also facilitate the sharing of best practices, lessons learned, and success stories, inspiring communities to implement similar initiatives and adapt them to their specific contexts.

Communication Challenges in Rural Nigeria

According to Adediran, Opadiji, Faruk, and Bello (2017), effective communication is vital for human interaction. However, in rural area in Nigeria like Ibaji Local Government Are, communication can be difficult because of various factors like inadequate infrastructure, cultural disparities, and low levels of literacy. These obstacles can impede the progress of rural entrepreneurs, invariably affecting economic growth and development in the same study zone.

Empirical Review

Empirical studies demonstrate the positive relationship between communication and entrepreneurial success. Conceptual frameworks linking communication to entrepreneurship emphasize the role of communication in accessing resources, building networks, and navigating institutional environments.

Mukelabai& Jackson (2021) studied the effects of effective communications on organizational performance using the systems theory. A quantitative approach was used to describe and analyse data collected for the study from 88 respondents. A questionnaire was used to identify factors affecting effective communication based on systems theory. Descriptive analysis and Pearson's correlation were used to analyse the results. The results for H_1 showed a Pearson correlation coefficient of 0.642 which is statistically insignificant if the (sig. 2-tailed) < 0.05 indicating that there was no statistically significant relationship between management and channel of communication used. However, the results from H_2 indicated that there was a relationship between channel of communication used and effective communication with a Pearson correlation coefficient of 0.041 at (sig. 2-tailed) < 0.05. Lastly the correlation results from H_3 showed that effective communication has a positive effect on organizational performance.

Alobele, (2023) studied Communication Strategies for Enhancing Community Development and Participation in Rural Communities in Nigeria. The study focuses on the importance of employing effective

communication strategies to enhance community development and participation in rural areas of Nigeria. Diffusion of Innovation Theory and the Social Capital Theory were discussed to provide a comprehensive understanding of communication strategies for community development. The research methodology employed in the study involves an extensive review of relevant literature sources, utilizing a synthetic analysis approach to identify patterns, themes, and key findings. The study proposes a number of communication strategies including participatory communication, integrated communication platforms, and capacity building in order to overcome these challenges. The findings highlight the importance of effective communication in bridging the gap between rural communities and stakeholders, promoting understanding and cooperation, and enabling inclusive decision-making processes.

Nweze (2019) examined the Role of Development Communication in the Development of Nigeria's Economy using historical method. Findings made from historical survey and analysis shows that development communication has been playing many roles toward development of Nigeria's economy. In view of this, it is recommended among others that Nigeria government should give financial supports to Nigerian mass media institution to enable it get better equipped for development communication in the interest of economic development in Nigeria.

Princi (2024) examines the Role of Effective Communication in the Growth and Development of Business Activities. The author noted that: in the realm of marketing and customer relations, effective communication is paramount. A well-crafted communication strategy sets businesses apart, attracts customers, and builds brand loyalty. Fast, efficient communication tools in today's digital age fuel growth by enabling rapid decision-making, problem-solving, and seamless collaboration across geographically dispersed teams. He concluded that, effective communication is a critical driver of business growth, transcending its traditional role as a support function to become a strategic necessity. By cultivating understanding, trust, innovation, and efficiency, robust communication underpins organizational success.

Theoretical Framework

The theory suit for this work is **The Shannon-Weaver model**. Communication theories, such as the Shannon-Weaver Model, highlight the importance of effective communication in business. The **Shannon-Weaver model** is one of the first and most influential models of communication. It was initially published in the 1948 paper "A

Mathematical Theory of Communication" and explains communication in terms of six basic components. The Shannon-Weaver model is based on the idea that communication is a linear and one-way process that involves six elements: a source, a transmitter, a channel, a receiver, a destination, and noise. The source is the person or entity that has a message to communicate. The transmitter is the device or medium that encodes the message into a signal that can travel through the channel. The channel is the path or medium that carries the signal from the transmitter to the receiver. The receiver is the device or medium that decodes the signal back into a message that can be understood by the destination. The destination is the person or entity that receives and interprets the message. Noise is any interference or distortion that affects the quality or clarity of the signal or message. In my word, the noise here refers to as externality that may likely affect the quality of message from the source to the receiver. The Shannon–Weaver model is graphically illustrated in figure 1 bellow.

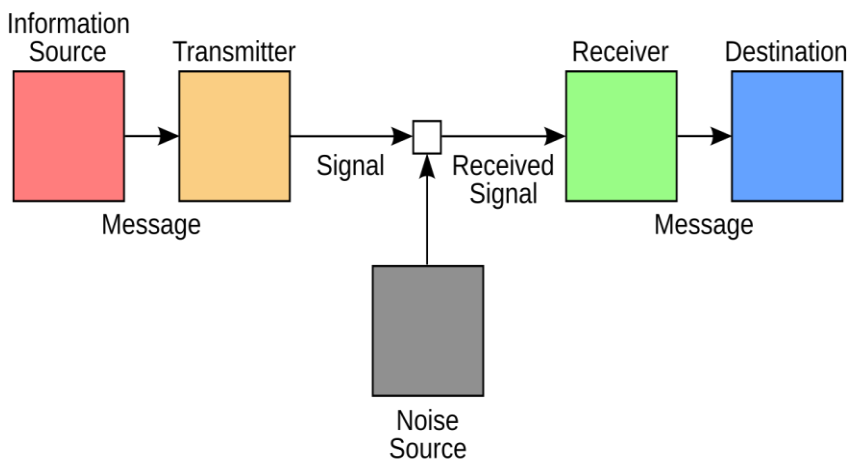

Fig. 1: The Shannon–Weaver model
Sources: google

Justification

The Shannon-Weaver model has several advantages for communications planning. First, it provides a simple and clear way to identify and analyze the key components and factors of any communication process. It helps to clarify the roles and responsibilities of the sender (the entrepreneur) and the receiver (the audience or customers), and to evaluate the effectiveness and efficiency of the transmission and reception of the message. Second, it helps to identify and reduce the sources and types of noise that can

affect communication, such as physical, semantic, psychological, or cultural noise. It also helps to choose the most appropriate and reliable channel and medium for delivering the message, depending on the context and purpose of communication. Third, it can be applied to various forms and levels of communication, such as interpersonal, group, organizational, mass, or digital communication. It can also be adapted and modified to suit different situations and scenarios, such as crisis communication, public relations, marketing, or education.

METHODOLOGY

This study employed a mixed-methods approach, combining survey research with case studies.

The study used a survey research design. According to Check & Schu (2012), survey research is "the collection of information from a sample of individuals through their responses to questions". This type of research design allows for a variety of methods to recruit participants, collect data, and utilize various methods of instrumentation.

The study was conducted in Ibaji Local Government Area (LGA) of Kogi State with headquarters at Onyedega. Ibaji LGA is located between latitude $7^{\circ} 00'$ - $8^{\circ} 50'$ N and longitude $7^{\circ} 30'$ - $8^{\circ} 00'$ E. It has ten council wards with an estimated population of 127,572 people comprising 64,423 males and 63,149 females (NPC, 2006).

The council wards are grouped into three districts; Onyedega, Unale and Ujeh. The land is a very fertile flood plain, suitable for agriculture and fishing. Most Ibaji people are entrepreneurs and they also produce rice, yam and cassava in large quantities. National Population Commission (NPC), Nigerian population census 2006 analysis, 2006.

The population of the study comprises the entrepreneurs in Ibaji Local Government Area of Kogi State. According to Churchill & Brown (2007), population refers to all the individuals or objects that meet certain requirements for membership in the overall group. Those who qualify are then referred to as the population elements. Cooper & Schindler (2003) also noted that, a population is the total collection of elements about which we wish to make inferences. The population that would be considered for this study includes entrepreneurs from Ibaji Local Area of Kogi State, Nigeria.

The study employed multi-stage sampling technique to randomly and proportionately select entrepreneurs engaged in production, food & beverages making, agriculture (farming, poultry, rice and yam) and trading (produce marketing) in Ibaji.

Five (5) wards would be randomly selected out of the existing ten wards (10) in the study area. These wards include; Analo, Odeke, Ejule, Akpanyo And Onyedga ward. These wards are selected due to large number of entrepreneurs in the study area. Simple random technique was used to randomly select a total sample size of 500 entrepreneurs from the study zone

Multi-Stage Sampling Technique

To select a representative sample from Ibaji Local Government Area (LGA) of Kogi State, this study employed a multi-stage sampling technique.

Stage 1: Cluster Sampling

Ibaji LGA into 10 clusters (corresponding to the 10 council wards) and Randomly select 5 clusters (wards) using simple random sampling (SRS)

Stage 2: Stratified Sampling

- Within each selected cluster (ward), stratify the population into two strata:

1. Males (64,423)
2. Females (63,149)

- Allocate sample size proportionally to each stratum

Stage 3: Systematic Random Sampling

Within each stratum, use systematic random sampling to select participants from every 10th household/business/entrepreneur

Sample Size Determination

- Estimated population: 127,572
- Desired precision: 95% confidence level, 5% margin of error
- Sample size calculator or formula (e.g., Cochran's formula) yields a sample size of 384

Table 1: Sample Distribution

s/n	Selected wards from the study area (Ibaji LGA)	Sample size for the study
1	ANALO	50
2	ODEKE	100
2	EJULE	74
4	AKPANYO	80
5	ONYEDEGA	80
	TOTAL	384

- 5 selected clusters (wards): $384 / 5 = 76.8$ (round to 77) participants per cluster
- Male stratum: $64,423 / 127,572 \approx 50.5\%$ of sample (195 participants)
- Female stratum: $63,149 / 127,572 \approx 49.5\%$ of sample (189 participants)

This multi-stage sampling technique ensures representation from various wards and stratifies the sample by gender, providing a reliable and generalizable sample for the study.

Primary data was collected with aid of self-developed structured questionnaire via face-to-face interview. The questionnaire was administered by the researcher alongside trained enumerators in the selected wards of Ibaji local government area. A pre-test was conducted on the questionnaire to ascertain its quality, suitability and usability; use the findings of the pre-test to fine-tune the questionnaire; and checkmate the adequacy of respondent.

The qualitative and quantitative methods of data analysis was used to analyze the data generated. While the qualitative method was used to give interpretation to the data generated, the quantitative method was used to analyze the data using frequency distribution tables.

Analysis was done using both descriptive and inferential statistics. The descriptive statistics provided simple summaries about the sample that was measured, while the inferential statistics is used to derive conclusion from the data. Using 4-likert scale. The decision rule will be base on accepting the weighted mean of 2.5 and above and rejecting less than 2.5 and below.

Results

The data collected was analyzed to correspond with each research question. Therefore, frequency distribution tables were used in relation to the demographic and psychographic data to display the respondents' opinions and views.

Description of Sample

Demographic data

Table 2: Gender distribution of the respondents

Gender	Frequency	Percentage (%)
Male	195	50.5%
Female	189	49.5%
Total	384	100

Analysis of the table above shows that 50.5% of the respondents are male while 49.5% of the respondents are female.

Table 3: Age distribution of the respondents

Age Bracket	Frequency	Percentage (%)
20-99	111	27%
30-39	135	36%
40-49	76	21%
50& above	60	16%
Total	384	100%

Table 4.3, shows that 135(36%) of the respondents are within the age bracket of 30-39. Following that, 111(27%) of the respondents are within the age bracket of 20-29, 76 (21%) are within the age bracket of 40-49 while 60 (16%) of the respondents are within the age bracket of 50 and above.

Table 4: Research Objective 1: How does effective communication influence entrepreneurial growth in Ibaji Local Government Area?

S/ N	Items	S	A	S D	D	Weighted Mean	Decision rules
1	Communicate with stakeholders (customers, suppliers, partners)	200	180	3	1	3.50	Accepted
2	Effectiveness of communication skills improve entrepreneurial growth	80	300	4	0	3.19	Accepted
3	Effective communication led to increased sales and revenue	210	170	0	4	3.35	Accepted
4	Communication in your business decision-making process	100	249	25	10	3.14	Accepted

From table 4 above, 80% of respondents (200+180) agree/strongly agree on the importance of communicating with stakeholders. Similarly, 95% of

respondents (80+300) agree/strongly agree that effective communication skills improve entrepreneurial growth. While 95% of respondents (210+170) agree/strongly agree that effective communication leads to increased sales and revenue. Communication in business decision-making with Weighted mean of 3.14 also imply that 87% of respondents (100+249) agree/strongly agree on the importance of communication in business decision-making.

Table 5: Research Objective 2. What communication strategies can enhance economic growth and development in Ibaji Local Government Area?

S/N	Items	S	A	SD	D	Weighted Mean	Decision rules
1	Attend communication-related training or workshops for capacity building	250	107	-	27	3.51	Accepted
2	Utilizing technology for business communication through Video conferencing/Instant messaging, networking	79	290	10	5	3.13	Accepted
3	Advertising as one of the communication strategies for entrepreneurial success	202	156	11	15	3.41	Accepted
4	Effective communication plays vital roles in business innovation	211	169	1	3	3.53	Accepted

Table 5 above indicate that, 95% of respondents (250+107) agree/strongly agree on the importance of communication training for capacity building while 5% and below disagreed the assertion that effective communication training has no significant effects of business growth. 90% of respondents

(79+290) agree/strongly agree on utilizing technology for business communication.

Regarding advertising, 92% of respondents (202+156) agree/strongly agree on advertising as a vital communication strategy to boot or enhance entrepreneurial success. For effective communication in innovation, 96% of respondents (211+169) agree/strongly agree that effective communication plays a vital role in business innovation.

Table 6: Research Objective 3: What is the current state and challenges of entrepreneurship in Ibaji Local Government Area?

S/ N	Items	S	A	S D	D	Weighted Mean	Decision rules
1	Inappropriate communication channel to access fund	80	281	20	3	3.13	Accepted
2	Lack of appropriate communication channels do affective business	301	79	2	2	3.51	Accepted
3	Lack of infrastructure are the major challenges facing business in the area	209	170	0	4	3.35	Accepted
4	Lack of access to information on business opportunities and resources	22	60	15 2	1 5 0	1.88	Rejected
5	Lack of strategic communication support services to enhance your business growth	79	290	10	5	3.13	Accepted

From table 6 above, Inappropriate communication channel to access funds with the Weighted mean of 3.13, that is, 90% of respondents (80+281) agree/strongly agree that inappropriate communication channels hinders access to funds, and also 95% of respondents (301+79) agree/strongly agree that lack of suitable communication channels affects

business operation in the study area. Similarly, 95% of respondents (209+170) agree/strongly agree that infrastructure deficiencies are major challenges confronting entrepreneurs in Ibaji Local Government Area of Kogi State. 55% of respondents (22+60) disagree/strongly disagree that lack of access to information for business opportunities and resources is not significant issue in the study area. While 90% of respondents (79+290) agree/strongly agree that lack of strategic communication support hinders business growth in the Ibaji.

Discussion Of Finding

Findings support the importance of effective communication in enhancing entrepreneurial success. Comparison with existing literature highlights the need for context-specific communication strategies. Implications for policy and practice include:

Research question 1: the result from the weighted mean scores indicate a positive attitude towards the importance of effective communication in entrepreneurial growth. It worth note that entrepreneurs in this area, valued the importance of communicating with stakeholders such as customers, suppliers and partners, this invariably leads to high productivity/sale there by increase revenue, that foster growth and development. This is in line with the work of Princi (2024) who examine the role of Effective Communication in the Growth and Development of Business Activities, noted that “a well-crafted communication strategy sets businesses apart, attracts customers, and builds brand loyalty”. He further explained that efficient communication tools in today's digital age fuel growth by enabling rapid decision-making, problem-solving, and seamless collaboration across geographically dispersed teams. He concluded that, effective communication is a critical driver of business growth, transcending its traditional role as a support function to become a strategic necessity The results suggest that effective communication is highly valued among entrepreneurs in Ibaji Local Government Area, and it has a significant impact on their business growth and decision-making processes. In the same vein, Alobele (2023) noted that, empowering entrepreneurs with effective communication strategies bridging the gap between rural communities and stakeholders, promoting understanding and cooperation, and enabling inclusive decision-making processes. Mukelabai & Jackson (2021) stated that effective communication has a positive effect on organizational performance.

Research question 2: The results from table 5 highlight the importance of communication-related training, technology adoption,

advertising, and effective communication in driving business innovation and entrepreneurial success in Ibaji Local Government Area. The summary of the result suggested that the need to; (i) Provide communication training/workshops for entrepreneurs, (ii) encourage technology adoption for business communication, (iii) develop effective advertising strategies and (iv) emphasize effective communication in business innovation. This is because ,95% of respondents strongly agree on the importance of communication training for capacity building while 5% and below disagreed the assertion that effective communication training has no significant effects of business growth. 90% of respondents strongly agree on utilizing technology for business communication. Regarding advertising, 92% of respondents agree on advertising as a vital communication strategy to boot or enhance entrepreneurial success. For effective communication in innovation, 96% of respondents agree that effective communication plays a vital role in business innovation.

Research question 3: The results from table 6 highlight key areas for improvement to support entrepreneurial growth in Ibaji Local Government Area, particularly communication channels, infrastructure, and strategic communication support. The result indicates that entrepreneurs in Ibaji Local Government Area face challenges related to communication, infrastructure deficiencies are major challenges confronting entrepreneurs in the area. 55% of respondents disagree/strongly disagree that lack of access to information for business opportunities and resources is not significant issue in the study area. While 90% of respondents agree that lack of strategic communication support hinders business growth in the Ibaji area. The above result is in junction with the views of Adediran, Opadiji, Faruk, and Bello (2017), who noted that in rural area in Nigeria, communication can be difficult because of various factors like inadequate infrastructure, cultural disparities, and low levels of literacy. These obstacles can impede the progress of rural entrepreneurs, invariably affecting economic growth and development.

Summary and Conclusion

Empowering entrepreneurs with adequate and effective communication strategies is a pathway to entrepreneurial success. Effective communication stands as the bedrock of entrepreneurial success, business growth and development, intricately woven into every aspect of organizational life. By cultivating a culture of openness, transparency, and collaboration, businesses can unlock the full potential of their workforce,

drive innovation, and foster enduring relationships with customers, suppliers, investors, and other stakeholders. As businesses navigate the complexities of an increasingly interconnected and competitive landscape, communication excellence will remain a strategic imperative for achieving sustainable entrepreneurial success, economic growth and development. Entrepreneurship development can foster economic growth and development primarily by generating employment and foster the growth of micro, small and medium enterprises in Nigeria.

Recommendations

This study demonstrates the critical role of effective communication in empowering entrepreneurs and driving economic growth in Ibaji Local Government Area. Recommendations provide a roadmap for stakeholders to support entrepreneurship and economic development

1. From the finding, there is a need to develop a Communication Strategy for Entrepreneurs in Ibaji Local Government Area should develop a comprehensive communication strategy to enhance their business growth.
2. Entrepreneurs should invest in communication skills training to improve their ability to effectively communicate with stakeholders.
3. Establish business incubators to provide resources and support
4. Implement policy interventions to support entrepreneurship, such as tax incentives, grants and access to finance.

References

- Acemoglu, D., & Robinson, J. A. (2012). *Why nations fail: The origins of power, prosperity, and poverty*. Crown Business.
- Adediran, Y. A., Opadiji, J. F., Faruk, N., & Bello, O. W. (2017). Issues and challenges of rural telecommunications access in Nigeria. *Journal of Information Technology Impact*, 17(1), 1-12.
- Adejumo, D. (2001). Entrepreneurship and economic development. *Journal of Business and Entrepreneurship*, 13(1), 1-12.
- Akerlof, G. A. (1970). The market for lemons: Quality uncertainty and the market mechanism. *Quarterly Journal of Economics*, 84(3), 488-500.
- Alobele , I. A. (2023) *Communication Strategies for Enhancing Community Development and Participation in Rural Communities*

- in Nigeria. *International Journal of Innovative Information Systems & Technology Research* 11(3):26-40, July-Sept, 2023
- Ayandike, M. N., Emeh, Y. E., & Ukah, U. (2012). Entrepreneurship: A veritable tool for economic development. *Journal of Entrepreneurship and Business Innovation*, 1(1), 1-12.
- Bartlett, C. A., & Ghoshal, S. (1989). *Managing across borders: The transnational solution*. Harvard Business School Press.
- Brennan, N. M., and Doris M. M. (2018) "Do firms effectively communicate with financial stakeholders? A conceptual model of corporate communication in a capital market context." *Accounting and Business Research* 48(5): 553-577.
- Burt, R. S. (1992). *Structural holes: The social structure of competition*. Harvard University Press.
- Charles, K. (1998) *Peak Performance the art of communication*. Black enterprise. *International Digital Organization for Scientific Research* ISSN: 2579-0773 Idosr *Journal of Arts And Humanities* 4(1):126-136, 2019.
- Chesbrough, H. W. (2003). *Open innovation: The new imperative for creating and profiting from technology*. Harvard Business School Press.
- Coase, R. H. (1937). The nature of the firm. *Economica*, 4(16), 386-405.
- Dickson, P. H., Solomon, G. T., & Weaver, K. M. (2008). Entrepreneurial selection and success: Does education matter? *Journal of Small Business Management*, 46(3), 357-376.
- Dunning, J. H. (2000). The eclectic paradigm as an envelope for economic and business theories of MNE activity. *International Business Review*, 9(2), 163-190.
- Field, J. (2005). *The role of communication in rural development*. *Journal of International Development*, 17(6), 821-838.
- Fukuyama, F. (1995). *Trust: The social virtues and the creation of prosperity*. Free Press.
- Granovetter, M. S. (1973). The strength of weak ties: A network theory revisited. *American Journal of Sociology*, 78(6), 1360-1380.
- Gupta, A. K., & Govindarajan, V. (2000). Managing your innovation's dark side. *Harvard Business Review*, 78(1), 166-173.
- International Telecommunication Union (ITU). (2020). *ICT Development Index*.
- Naude, W. (2013). *Entrepreneurship and economic development*.

- Nwaeze, S.(2019). *The Role of Development Communication in the Development of Nigeria's Economy*. Department of Mass Communication Ebonyi State University, Abakaliki
- Princi, T. (2024) Role of Effective Communication in the Growth and Development of Business Activities. *Research Association For Interdisciplinary Studies*. Latvia,
- Schumpeter, J. A. (1934). *The Theory of Economic Development: An Inquiry into Profits, Capital, Credit, Interest, and the Business Cycle*. Harvard University Press.
- Wennekers, S., & Thurik, R. (1999). Linking entrepreneurship and economic growth.